

CUT FREESTYLE

PROJECT: #25121

Difficulty Rating:



What you will need:

- 1 x Artwork
- 1 x Matboard
- 1 x Stencil
- 1 x GrooveMaster
- 1 x Document Cleaning Pad
- 1 x Matboard



#14400 GrooveMaster™ V-Groove Kit



#17453 Document Cleaning Pad

Turn your GrooveMaster into a versatile free hand cutting tool by changing the blade setting.

Remove one blade carefully, or retract it so that it will not cut the board. Lower the other blade further out so that it just cuts all the way through the board you are cutting. Ideas for cut outs, come from stencils, rubber stamps, cartoons etc. When selecting a particular shape to cut out, pick a shape that does not have any tight curves. If it does then try substituting the tight curve with a point eg. a cats tail or dolphins fin...this will make the job much easier. Simply trace around the stencil onto the face of the mount board, then cut out the pattern (see figures 1 - 4).

Handy Hints

Hint 1 Use a scrap piece of matboard in between the mount being cut and the cutting mat. This allows the mount to be turned alot easier whilst cutting out the shape. It is easier because the blade is cutting into your scrap piece of matboard rather than the cutting mat.

Hint 2 Practice. Practice. Try and develop the technique of actually moving the cutter prior to turning it. This should achieve a much smoother curve. Remember move first and turn second, move...turn, move...turn.

Hint 3 If you happen to veer off the drawn line, this is considered "Artistic Licence" the lines are a guide only. Just keep cutting smoothly and carefully bring the cut back in line with the line.

Hint 4 When cutting out shapes, you cut from the front of the board. This will result in clean smooth cut shapes.

Hint 5 When cutting freehand windows, cut from the back of the board as this will assist in measuring and layout. It is normal practice to finish off corners with a spare blade.

Hint 6 To better enhance a cut-out shape, try integrating a shadow effect of the shape in your main window. Remember that you cut out the shadow from the back of the mat board. fig 5.

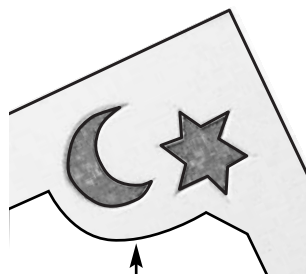
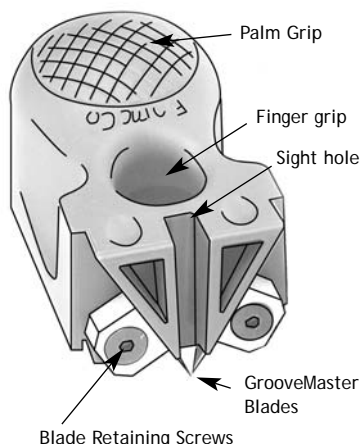

fig. 5 The shadow effect in the main window highlight the cut-out shape.

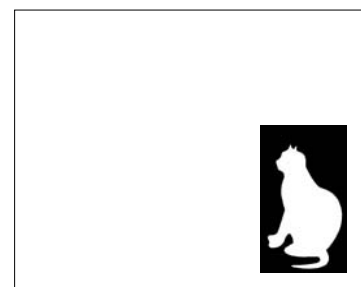

fig. 1 You can purchase stencils from craft or hardware stores.

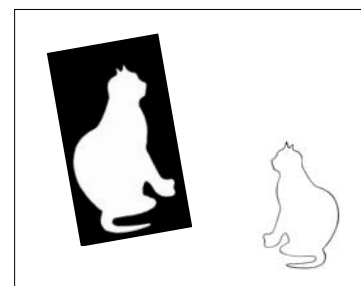

fig. 2 Trace around the stencil.

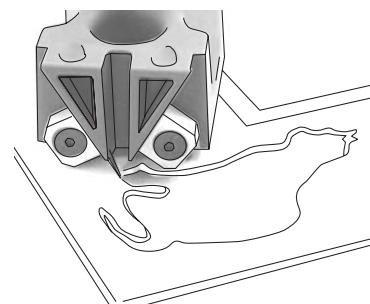

fig. 3 Position the GrooveMaster over the line and cut along the line.

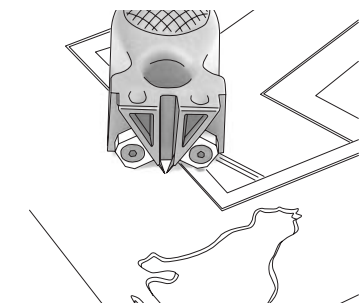

fig. 4 The GrooveMaster creates endless possibilities!

FrameCo - Australia
 Email: frame@frameco.com.au

FrameCo - Euro / U.K.
 Email: frame.uk@clubframeco.com

FrameCo - U.S.A.
 Email: info.usa@clubframeco.com